

The Differential of a Function of Several Variables

Guoning Wu

April 28, 2019

1 Double Integral

1.1 Introduction

Volume Problem: Find the volume V of the solid G enclosed between the surface $z = f(x, y)$ and the region R in the xy -plane where $f(x, y)$ is continuous and non-negative on R .

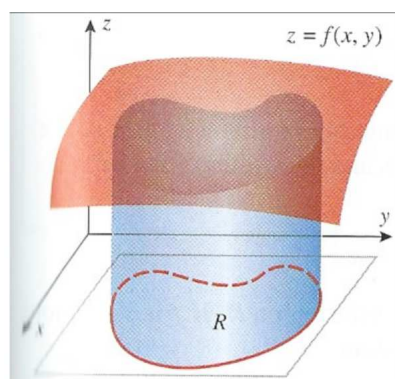

Figure 1: Volume.

Mass Problem: Find the mass M of a lamina (a region R in the xy -plane) whose density is a continuous nonnegative function $\rho(x, y)$

Let us consider the Volume Problem,

1. Divide the rectangle enclosing R into subrectangles, and exclude all those rectangles that contain points outside R . Let n be the number of all the rectangles inside R , and let $\Delta A_k = \Delta x_k \Delta y_k$ be the area of the k -th subrectangle.

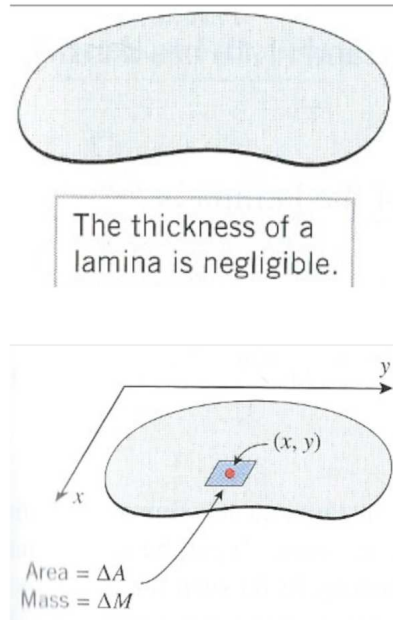

Figure 2: Mass.

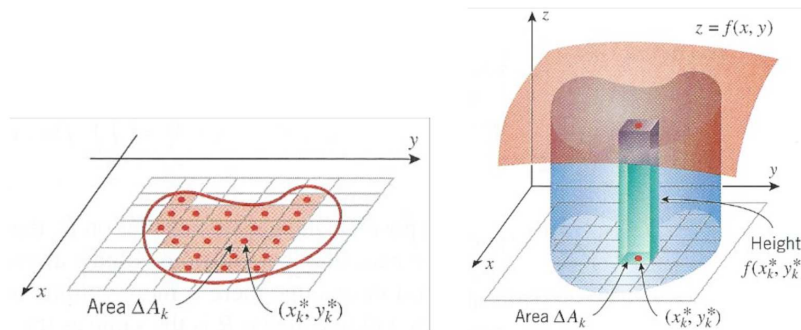

Figure 3: Volume.

2. Choose any point (ξ_k, η_k) in the k -th subrectangle. The volume of a rectangular parallelepiped with base area ΔA_k and height $f(\xi_k, \eta_k)$ is $\Delta V_k = f(\xi_k, \eta_k)\Delta A_k$, thus,

$$V \approx \sum_{k=1}^n \Delta V_k = \sum_{k=1}^n f(\xi_k, \eta_k)\Delta A_k = \sum_{k=1}^n f(\xi_k, \eta_k)\Delta x_k\Delta y_k \quad (1)$$

This sum is called the *Riemann sum*.

3. Take the sides of all the subrectangles to 0, and get

$$V = \lim_{\lambda(P) \rightarrow 0} \sum_{k=1}^n f(\xi_k, \eta_k)\Delta A_k = \iint_R f(x, y) \, dA \quad (2)$$

The last term is the notation for the limit of the Riemann sum, and it is called the *double integral* of $f(x, y)$ over R .

1.2 The Darboux Criterion

Let us consider another criterion for Riemann integrability of a function, which is applicable only to real-valued function. Lower and Upper Darboux Sums. Let f be a real-valued function on the interval I and $P = I_i$ a partition of the interval I . We set

$$m_i = \inf_{x \in I_i} f(x), M_i = \sup_{x \in I_i} f(x). \quad (3)$$

The quantities

$$s(f, P) = \sum_i m_i |I_i|, S(f, P) = \sum_i M_i |I_i| \quad (4)$$

are called the *lower* and *upper sums* of the function f over the interval I corresponding to the partition P of the interval.

The following relations hold between the Darboux sums a a function $f : I \rightarrow \mathbb{R}$:

1. $s(f, P) = \inf_{\xi} \sigma(f, P, \xi) \leq \sigma(f, P, \xi) \leq \sup_{\xi} \sigma(f, P, \xi) = S(f, P)$
2. If the partition P' of the interval I is obtained by refining intervals of the partition P , then $s(f, P) \leq s(f, P') \leq S(f, P') \leq S(f, P)$
3. The inequality $s(f, P_1) \leq S(f, P_2)$ holds for any pair of partition P_1, P_2 of the interval I .

1.3 Lower and Upper Integrals

The lower and upper Darboux integrals of the function $f : I \rightarrow \mathbb{R}$ over the interval I are respectively

$$\underline{I} = \sup_P s(f, P), \bar{I} = \inf_P S(f, P) \quad (5)$$

where the supremum and infimum are taken over all partitions P of the interval I .

Theorem 1.1. *For any bounded function:*

$$f : I \rightarrow \mathbb{R}, \lim_{\lambda(P) \rightarrow 0} s(f, P) = \underline{I}, \lim_{\lambda(P) \rightarrow 0} S(f, P) = \bar{I}$$

1.4 The Darboux Criterion for Integrability of a Real-valued Function

Theorem 1.2 ((The Darboux Criterion). *A real valued function $f : I \rightarrow \mathbb{R}$ defined on an interval $I \subset \mathbb{R}^{\times}$ is integrable over that interval if and only if it is bounded on I and its upper and lower Darboux integrals are equal.*

$$f \in \mathcal{R}(I) \equiv f \text{ is bounded on } I, \text{ and } \underline{I} = \bar{I}.$$

1.5 Double Integral Over Non-rectangular Regions

$$\int_a^b \int_c^d f(x, y) dy dx = \int_a^b \left[\int_c^d f(x, y) \right] dx \quad (6)$$

$$\int_a^b \int_{g_1(x)}^{g_2(x)} f(x, y) dy dx = \int_a^b \left[\int_{g_1(x)}^{g_2(x)} f(x, y) dy \right] dx \quad (7)$$

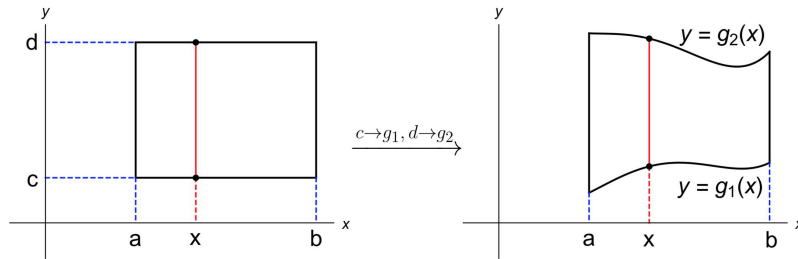

Figure 4: Double Integral.

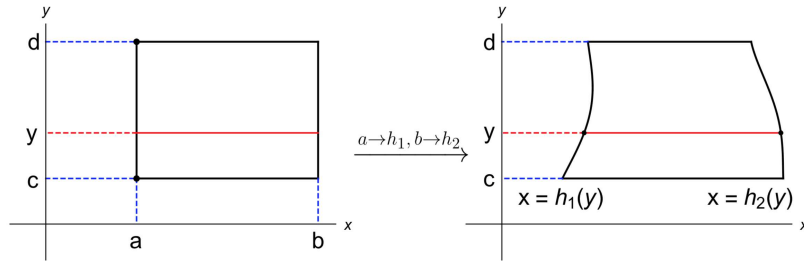

Figure 5: Double Integral.

$$\int_a^b \int_{h_1(y)}^{h_2(y)} f(x, y) dx dy = \int_a^b \left[\int_{h_1(y)}^{h_2(y)} f(x, y) dx \right] dy \quad (8)$$

Examples 1. 1. $\int_0^1 \int_1^2 \sin(2x - 3y) dx dy$

2. $\int_1^2 \int_0^1 \sin(2x - 3y) dy dx$

Theorem 1.3. Let D be the rectangle $[a, b] \times [c, d]$. If $f(x, y)$ is continuous on D then

$$\iint f(x, y) d\sigma = \int_a^b \int_c^d f(x, y) dy dx = \int_c^d \int_a^b f(x, y) dx dy$$

Examples 2. Find the volume V of the solid enclosed by the surfaces $z = 0$, $y^2 = x$, $x + z = 1$

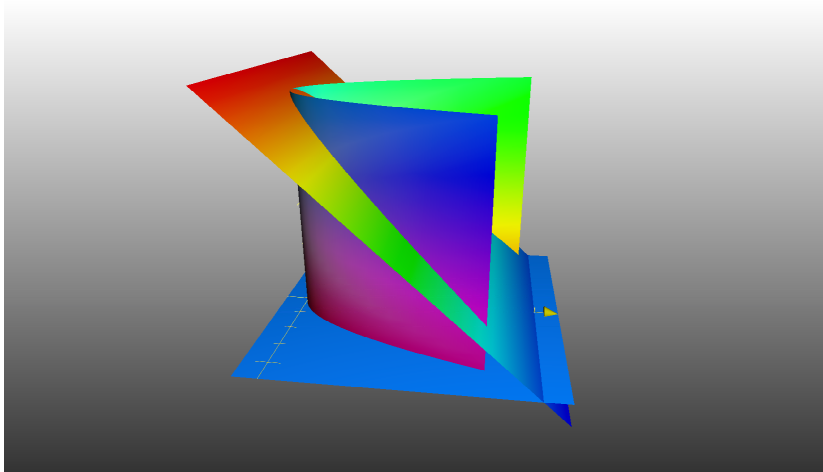

Examples 3. Reverse the order of the integrals below:

- $\int_a^b dx \int_a^x f(x, y) dy$

- $\int_0^1 dy \int_0^{2y} f(x, y) dx + \int_1^3 dy \int_0^{3-y} f(x, y) dx$

1.6 Double integrals in polar coordinates

Let us consider the volume problem in polar coordinates

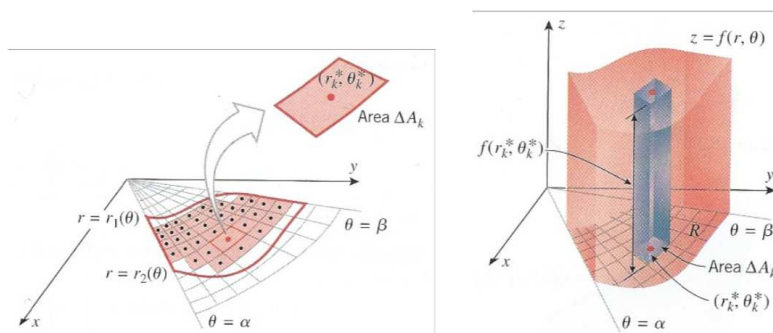

$$\iint_D f(x, y) d\sigma = \int_{\alpha}^{\beta} d\theta \int_{r_1(\theta)}^{r_2(\theta)} f(r, \theta) r dr$$

Examples 4.

$$\iint_D \frac{d\sigma}{\sqrt{1-x^2-y^2}}$$

$$D : \{(x, y) \mid x^2 + y^2 \leq 1\}$$

Examples 5. Compute the volume of the Figure(1.6), which the surfaces are

$$x^2 + y^2 + z^2 \leq R^2, x^2 + y^2 = Rx$$

Examples 6.

$$\iint_D e^{-(x^2+y^2)} d\sigma.$$

$$D : x^2 + y^2 \leq R^2$$

Examples 7. Compute the volume

$$\frac{x^2}{a^2} + \frac{y^2}{b^2} + \frac{z^2}{c^2} \leq 1$$

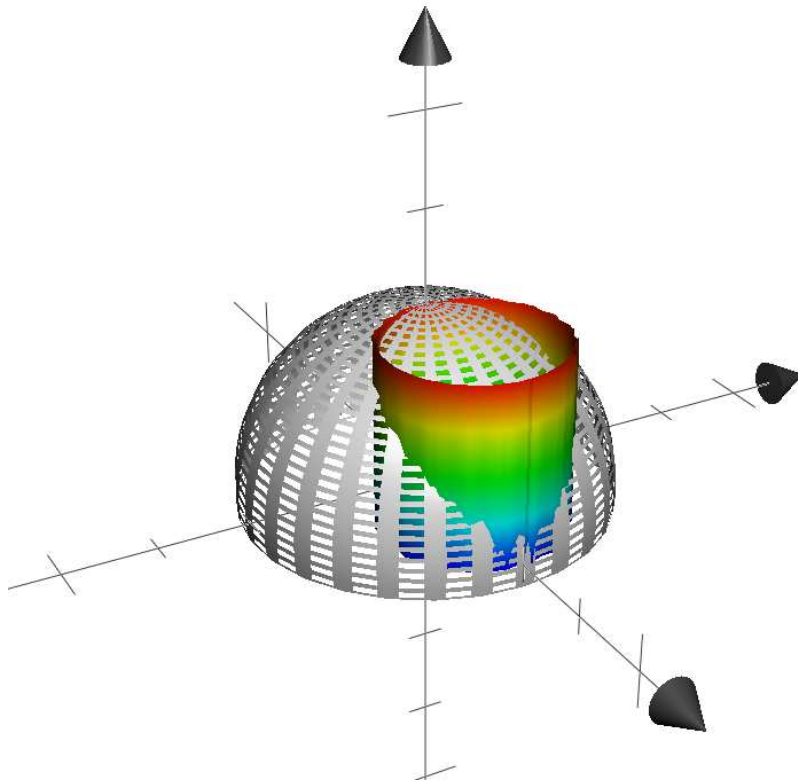

Figure 6: Volume.

Examples 8.

$$\iint_D e^{\frac{x-y}{x+y}} d\sigma.$$

$$D : x + y \leq 1, x \geq 0, y \geq 0.$$

Examples 9.

$$\int_{-\infty}^{+\infty} e^{-x^2} dx = \sqrt{\pi}$$

1.7 Triple Integrals

Find the mass M of a solid G whose density (the mass per unit volume) is a continuous nonnegative function $\rho(x, y, z)$.

1.7.1 Evaluating triple integrals over rectangular boxes

$$\iiint_G f(x, y, z) dv = \int_a^b dx \int_c^d dy \int_k^l f(x, y, z) dz$$

$$\iiint_G f(x, y, z) dv = \iint_D d\sigma \int_{z_1(x,y)}^{z_2(x,y)} f(x, y, z) dz$$

$$\iiint_G f(x, y, z) dv = \int_a^b dx \iint_D f(x, y, z) d\sigma$$

Examples 10.

$$\iiint_V \frac{dx dy dz}{x^2 + y^2}$$

$$V : x = 1, x = 2, z = 0, y = x, z = y$$

Examples 11.

$$\iiint_V (x^2 + y^2 + z) dx dy dz$$

$$V : z = \sqrt{x^2 + y^2}, z = 1$$

Examples 12.

$$\iiint_V \left(\frac{x^2}{a^2} + \frac{y^2}{b^2} + \frac{z^2}{c^2} \right) dv$$

$$V : \frac{x^2}{a^2} + \frac{y^2}{b^2} + \frac{z^2}{c^2} \leq 1$$

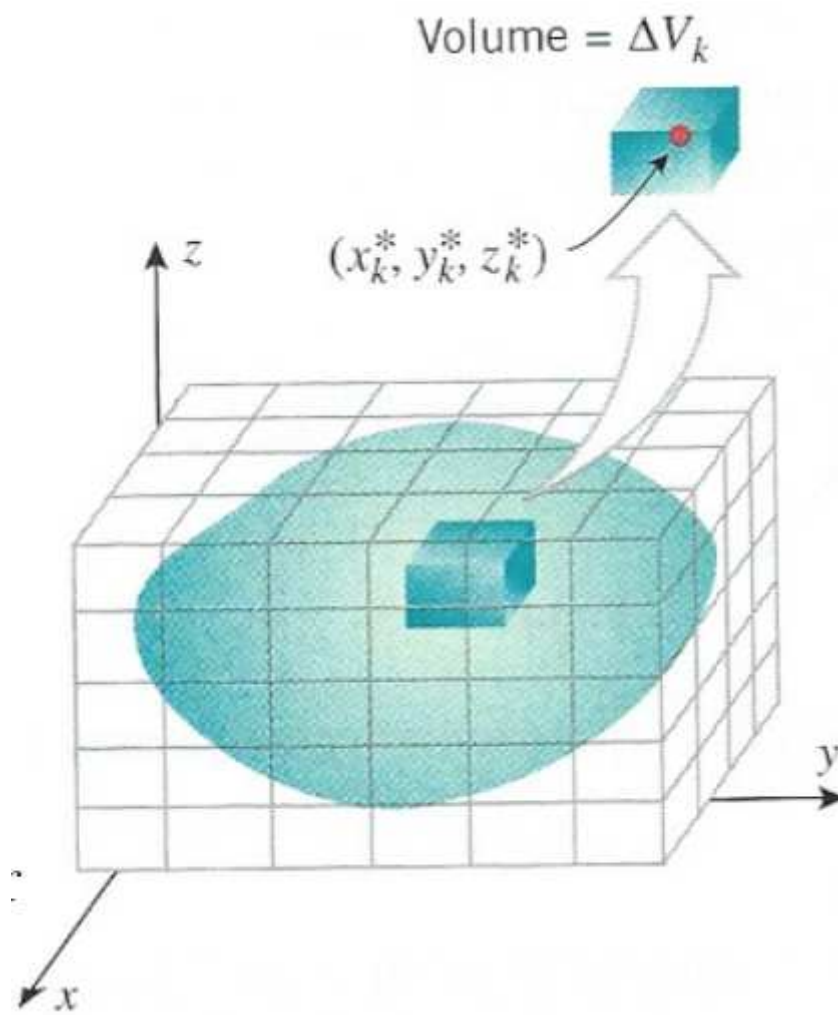

Figure 7: Mass.

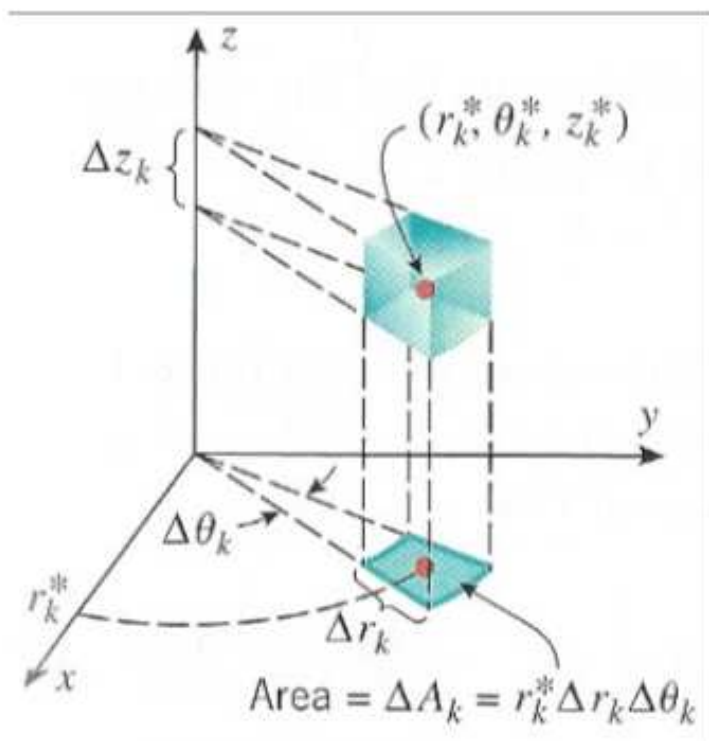

Figure 8: Cylindrical.

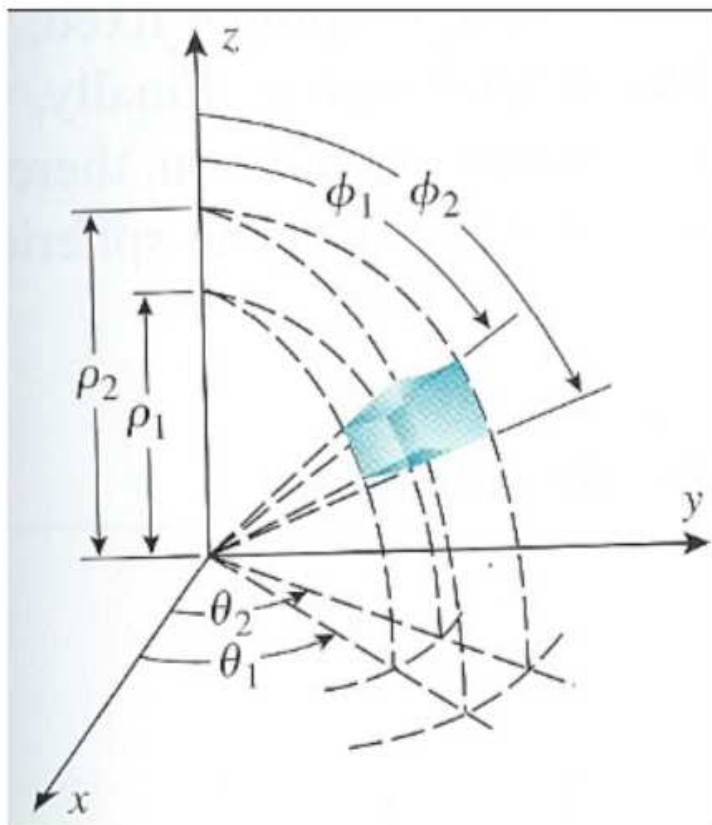

Figure 9: Spherical.

1.7.2 Triple integrals in cylindrical and spherical coordinates

$$\iiint_V f(x, y, z) \, dv = \iiint_{V'} f(r \cos \theta, r \sin \theta, z) r \, dr d\theta dz.$$

$$\iiint_V f(x, y, z) \, dv = \iiint_{V'} f(r \sin \phi \cos \theta, r \sin \phi \sin \theta, r \cos \phi) r^2 \sin \phi \, dr d\phi d\theta.$$

Examples 13.

$$\iiint_{\omega} (x^2 + y^2) \, dv,$$

ω is the volume bounded by surfaces $z = x^2 + y^2, z = h$

Examples 14.

$$\iiint_{\omega} z e^{-(x^2+y^2+z^2)} \, dv,$$

ω is the volume bounded by surfaces $z = \sqrt{x^2 + y^2}, x^2 + y^2 + z^2 = 1$

Examples 15. Compute the volume of the $\frac{x^2}{a^2} + \frac{y^2}{b^2} + \frac{z^2}{c^2} \leq 1$

Examples 16. Compute the volume of $x_1^2 + x_2^2 + \cdots + x_n^2 \leq R^2$

Examples 17. Compute the area inside $(x - y)^2 + x^2 = a^2 (a > 0)$.

Examples 18. Compute the area bounded by $xy = p, xy = q, y = ax, y = bx$.

Examples 19. Compute the volume bounded by $(x^2 + y^2)^2 + z^4 = y$.

Examples 20. Compute the volume bounded by $x_1^2 + x_2^2 + \cdots + x_n^2 \leq R^2$.

2 作業

1. 根據二重積分的性質，比較下列積分的大小

(a) $\iint_D (x+y)^2 dx dy, \iint_D (x+y)^3 dx dy$ ，其中 D 為 x 軸， y 軸與直線 $x+y=1$ 所圍成的區域。

(b) $\iint_D \ln(x+y) dx dy, \iint_D [\ln(x+y)]^2 dx dy$ ，其中 $D = [3, 5] \times [0, 1]$ 。

2. 計算下列重積分

(a) $\iint_D x^3 + 3x^2y + y^3 dx dy$ ，其中 $D = [0, 1] \times [0, 1]$ 。

(b) $\iint_D xy e^{x^2+y^2} dx dy$ ，其中 $D = [a, b] \times [c, d]$ 。

(c) $\iint_D xy^2 dx dy$ ，其中 D 由拋物線 $y^2 = 2px$ 和直線 $x = \frac{p}{2}$ ($p > 0$)所圍成的區域。

(d) $\iint_D e^{x+y} dx dy$ ，其中 D 為 $\{(x, y) \mid |x| + |y| \leq 1\}$ 所圍成的區域。

(e) $\iint_D x dx dy$ ，其中 D 為拱線的一拱 $x = a(t - \sin t), y = a(1 - \cos t)$ ($0 \leq t \leq 2\pi$)所圍成的區域。

3. 採用極坐標變換計算下列積分

(a) $\iint_D \sin \sqrt{x^2 + y^2} d\sigma, D = \{(x, y) \mid \pi^2 \leq x^2 + y^2 \leq 4\pi^2\}$

(b) $\iint_D (x+y) d\sigma, D = \{(x, y) \mid x^2 + y^2 \leq x+y\}$

(c) $\iint_D |xy| d\sigma, D = \{(x, y) \mid x^2 + y^2 \leq a^2\}$

(d) $\iint_D f'(x^2 + y^2) d\sigma, D = \{(x, y) \mid x^2 + y^2 \leq R^2\}$

4. 做適當的座標變換計算下列積分

(a) $\iint_D (x+y) \sin(x-y) d\sigma, D = \{(x, y) \mid 0 \leq x+y \leq \pi, 0 \leq x-y \leq \pi\}$

(b) $\iint_D e^{\frac{x}{x+y}} d\sigma, D = \{(x, y) \mid x+y \leq 1, x \geq 0, y \geq 0\}$

5. 計算下列幾何體的體積

(a) V 是由 $z = x^2 + y^2, z = x + y$ 所圍成的立體。

(b) V 是由 $z^2 = \frac{x^2}{4} + \frac{y^2}{9}$ 和 $2z^2 = \frac{x^2}{4} + \frac{y^2}{9}$ 所圍成的立體。

6. 選取適當的座標變換計算下列積分

(a) $\iiint_{\Omega} (x^2 + y^2 + z^2) dv$ 其中 Ω 為球 $x^2 + y^2 + z^2 \leq 1$

(b) $\iiint_{\Omega} \sqrt{1 - \frac{x^2}{a^2} - \frac{y^2}{b^2} - \frac{z^2}{c^2}} dv$ 其中 Ω 為球 $\frac{x^2}{a^2} + \frac{y^2}{b^2} + \frac{z^2}{c^2} \leq 1$

(c) $\iiint_{\Omega} \frac{z \ln(1 + x^2 + y^2 + z^2)}{1 + x^2 + y^2 + z^2} dv$ 其中 Ω 為球 $x^2 + y^2 + z^2 \leq 1, z \geq 0$

(d) $\iiint_{\Omega} (x + y - z)(x - y + z)(y + z - x) dv$ 其中 Ω 為 $0 \leq x + y - z \leq 1, 0 \leq x - y + z \leq 1, 0 \leq y + z - x \leq 1$

7. 計算下列積分

(a) $\int_{\Omega} \sqrt{x_1 + x_2 + \cdots + x_n} dv$ 其中 Ω 為 $x_1 + x_2 + \cdots + x_n \leq 1, x_i \geq 0 (i = 1, 2, \cdots, n)$

(b) $\int_{\Omega} \sqrt{x_1^2 + x_2^2 + \cdots + x_n^2} dv$ 其中 Ω 為 $x_1^2 + x_2^2 + \cdots + x_n^2 \leq 1$